

DATUM

Uni – Directional KNIFE GATE VALVE

Datum Knife Gate Valves are the most popular valve configuration specially designed for Isolation, On-Off, and modulating services in Power plants, Steel plants, Paper & Pulp Industries, Cement plants, Sugar Industries, Chemical & Textile processing Industries, Mining, Sewage boards to handle slurries, slag, pulp, fly ash, powders, gases.



Construction Features:

BODY	One piece Cast Steel, Stainless Steel, Cast Iron, Fabricated Steel for sizes beyond 30"
PORT DESIGN	Full port allows high flow capacity and low pressure drop
FLANGES	Wafer design – Flanged, Full or semi lugged
DRILLING	As per ANSI, DIN and BS standards
GATE	Cast Steel, Stainless Steel, Special Alloys. The gate is ground and buffed on both sides to enhance packing life, jerk-free operation and ensure positive shut-off, beveled edge cuts through solid particles settled at bottom.
STEM	Stainless Steel or as per requirement, having double start threads for fast closing and opening, rising spindle type. Optional spindle cover to protect threaded area from dust/foreign particles
PACKING	Multilayer gland packing in various materials to suit application
SEAT	Metal seated for leakage rates upto class IV across port. Soft seat for tight shut-off in various materials to suit application.
ACCESSORIES	Deflection cone to ensure flow towards center to avoid entrapment of solid particles between seat and gate. Scour plate at bottom allows servicing of the valve without disturbing the line.
OPERATION	Hand wheel, Chain wheel, Gearbox, Pneumatic Cylinder, Electric Actuators

ASSOCIATED AUTOMATION PVT LTD

WORKS: 243, G.I.D.C. ANKLESHWAR, DIST. BHARUCH -393 002, Gujarat, INDIA.

Regd. Office: 75, Sanman Park Society, Manjalpur, Vadodara -390 011, Gujarat, INDIA.

• TEL: +91 265 3093989 • Fax: +91 265 2662578 • E-mail: sales@associatedautomation.com •

Maximum Working Pressure

Valve working Pressure

50 mm – 300 mm : 150 psi

400 mm – 450 mm : 75 psi

500 mm – 600 mm : 50 psi

Body Test Pressure (before assembly)

Valve Size	St. Steel	C.I.
------------	-----------	------

50 mm – 350 mm	225 psi	150 psi
----------------	---------	---------

400 mm – 600 mm	100 psi	100 psi
-----------------	---------	---------

Above 600 mm	50 psi	50 psi
--------------	--------	--------

Manufacturing and Testing Standard: MSS – SP – 81

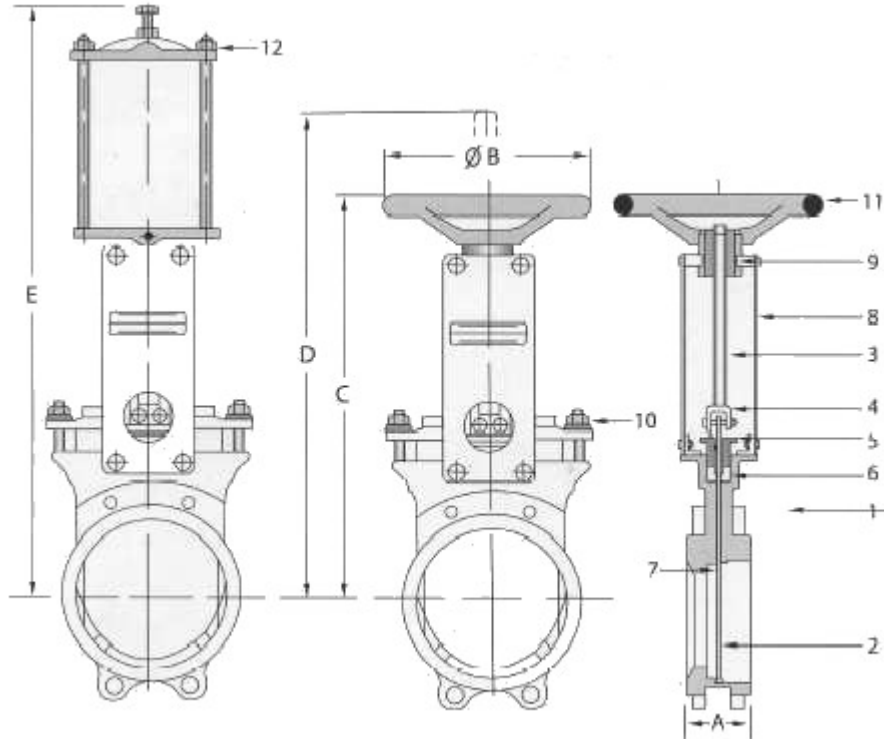

VALVE SIZE	DIMENSIONS IN MM				
	A	B	C	D	E
50	48	203	270	300	715
80	51	203	375	425	800
100	51	203	417	491	1000
125	57	254	470	561	1120
150	57	254	507	625	1200
200	70	305	607	775	1300
250	70	406	707	905	1500
300	76	406	796	1045	1785
350	76	508	890	1220	1890
400	89	508	900	1275	2100
450	89	508	1020	1450	2150
500	114	508	1150	1630	2300
600	114	508	1330	1915	2420

NO	PART	MATERIAL SPECIFICATION
1	BODY	ASTM A351 GR CF8/CF8M/CF3/CF3M ASTM A 216 GR WCB /IS210-FG260
2	GATE	ASTM A479 TY304/316/304L/316L
3	STEM / PISTON	ASTM A479 TY304/316/304L/316L / CHROME PLATED EN8
4	GATE ADAPTOR	ASTM A479 TY304/316/304L/316L
5	GLAND PUSHER	S.G. IRON
6	GLAND PACKING	PTFE IMPREGNATED ASBESTOR
7	SEAT	METAL INTEGRAL WITH BODY
		SOFT EPDM/VITON
8	YOKE	STEEL
9	YOKE	BRONZE
10	BOLTS/NUTS	ASTM A193 GR B7/A 194 GR 2H
11	HANDWHEEL	C.I.
12	PNEU. CYLINDER	AL./ CR PLATED STEEL

ASSOCIATED AUTOMATION PVT LTD

WORKS: 243, G.I.D.C. ANKLESHWAR, DIST. BHARUCH -393 002, Gujarat, INDIA.

Regd. Office: 75, Sanman Park Society, Manjalpur, Vadodara -390 011, Gujarat, INDIA.

• TEL: +91 265 3093989 • Fax: +91 265 2662578 • E-mail: sales@associatedautomation.com •